



Note for Completion of the Products Forms

The following information is absolutely necessary for us to allocate the zone, stand and booth. Please complete the following forms.

1. "Display Item Check Sheet" FORM-1: Please check all products to be exhibited

1. Please check all products to be exhibited, and also check three in order of priority.
 2. Please write down the type of products, if any out of list.
- *Please indicate clearly if you wish to exhibit such item as paint, oils, aerosols, etc.

2. "Display Item Report" FORM-2: The forms describing the products are the following

- CRAFTS
- ENGINES
- UTILITY VEHICLES (including camper and mobile home)

1. Please fill A to S code in the blank referring to the following "CODE LIST"
2. To fill in "manufacturer" and "Product Name (model) " columns, please write the official name in English.
3. All dimension should be written in meters and specified in terms of two digits below decimal point. Please refer to the following chart.

CODE LIST

CODE	ARTICLES	TYPE OF CRAFTS	
A	Motor boat	BOAT	CRAFTS
B	Inflatable		
C	Jet Boat		
D	Row Boat		
E	Other Boat		
F	Cruiser	YACHT	
G	Dinghy		
H	Standing	PERSONAL	
J	Sitting	WATER-CRAFT	
K	Outboard		
L	Inboard Engine	MARINE ENGINES	
M	In-Out Engine		
N	Electric Engine		
P	RV	UTILITY VEHICLES	
Q	Sedan		
R	Camper		
S	Mobile Home		

CHART (measurement)

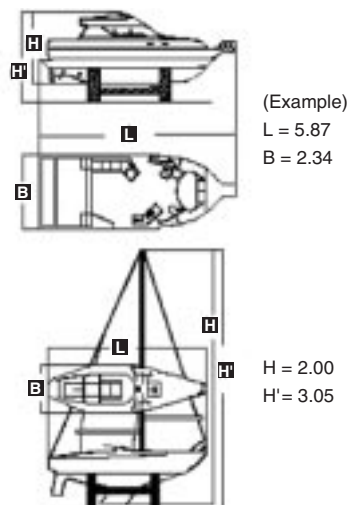



“Display Item Check Sheet” FORM-1

Please give priority order for the three main display items.

Date:

Your company's name:

Your name:

Tel.

Item	Priority	Details
Boats		Boat
		Sailboat
		PWC
Engines		Outboard motor
		Inboard motor
		Inboard outboard
PWC		Electric motor
		Recreational Vehicle (RV)
		Automobile
		Camping car
		Trailer house

Information about the items above must be fill out on the separate "Display Item Report"

Boats		Sailboat
		Surfboard
		Wakeboard
		Water skis
		Body board
		Other ()
Boat equipment		Anchor
		Chain
		Windlass
		Rope
		Roller
		Fender
		Propeller
		Other ()
Interior items		Carpet
		Antenna
		Water purifier
		Marine heater
		Audio
		Generator
		Pump
		Toilet
	Table	
		Other ()
Exterior items		Seat
		Horn
		Wipers
		Mirrors
		Navigation lights
		Searchlight
		Rudder
		Hardware
		Other ()
Steering		Hydraulic steering
		Auto pilot
		Steering mechanism

Item	Priority	Details	
Safety items		Lifejacket	
		Float	
		Other ()	
Instruments		GPS items	
		Fishfinder	
		Radar	
		Weather Fax	
		Wireless radio	
		Underwater camera	
		Binoculars	
		Other ()	
			Models
			Paintings
Decoration		Clocks	
		Tableware	
		Other ()	
			Oil
Maintenance		Paint	
		Tools	
		Wax	
		Batteries	
		Sprays	
		Other ()	
Accessories		Sunglasses	
		Pendants	
		Key holders	
		Watches	
		Other ()	
Apparel		Bathing suits	
		Hats	
		Wet suits	
		Shoes	
		Other ()	
Solicitations		Marine club membership	
		Marina membership	
		Rental club membership	
		License course	
		Other ()	
Others		Fishing gear	
		Diving gear	
		Camping gear	
		Trailer	
		Books	
		Sea maps	
		Others (Fill in contents below)	



“Display Item Report” FORM-2

Date:

Your company's name:

Your name:

Tel.

CRAFTS (CODE A to J)

Unit: m (record to two digits below the decimal point) (see example)

Item (use code letters a-j below)	Manufacturer name	Country of manufacture	Product name (model name)	Price Unit: ¥1,000	Overall length (L)	Overall width (B)	Overall Height (H) (including mast)	Overall Height (H') (for hull)

MARINE ENGINE (CODE K to N)

Unit: m (record to two digits below the decimal point) (see example)

Item (use code letters a-j below)	Manufacturer name	Country of manufacture	Product name (model name)	Price Unit: ¥1,000	Overall length (L)	Overall width (B)	Overall Height (H) (including mast)	Overall Height (H') (for hull)

UTILITY VEHICLES (CODE P to S)

Unit: m (record to two digits below the decimal point) (see example)

Item (use code letters a-j below)	Manufacturer name	Country of manufacture	Product name (model name)	Price Unit: ¥1,000	Overall length (L)	Overall width (B)	Overall Height (H) (including mast)	Overall Height (H') (for hull)



Exhibitor Application Form

Application deadline: Oct. 31 (Fri.), 2008, 17:00 hours

1. EXHIBITOR

Company			
Address			
URL	http://		
Person in charge	POSITION		
	NAME (please print) Mr. Ms.		
TEL:	FAX:	E-mail address:	

2. REPRESENTATIVE IN JAPAN (Embassy, official overseas organization or representative in Japan)

Organization			
Address			
Person in charge	POSITION		
	NAME (please print) Mr. MS		
TEL:	FAX:	E-mail address:	

3. EXHIBITION AREA REQUIRED

Number of Space Units	Number of Units: Type () (For types 4 and 12, choice (A) or (B) type. See Booth Units Layout)
Total Space Fee	¥

4. INDEX OF PRODUCTS

All products to be exhibited should be described in accordance with the application form-1.

5. PRODUCTS TO BE EXHIBITED

The detail of product, type and dimension, should be described in accordance with the application form-2.

6. PAYMENT REMITTANCE

The application fee is 50% of the total amount payable including tax. This sum should be transfer to the account below and a copy of the bank transfer slip should be attached over this space.

Bank name: Mizuho Bank, Ltd. Ginza-Chuo Branch, Tokyo (Swift Code No. MHBKJPJT)
Account name: Japan Boating Industry Association Boat Show Yokohama
Account No. : Account No. 1251138202

* The deadline for the balance of the space fee and all other costs is December 25 (Thursday), 2008.

I hereby explicitly accept the terms of Japan International Boat Show 2009 in Yokohama in all their respective parts.

NAME: _____ SIGNATURE: _____ DATE: _____